

# **UNI-VAC**

## **Model: 600 Series**

- **Cost Effective 1300 CFM Vacuum Booster**
- **Integral Bypass Eliminates Need For Pressure Switch**
- **Upgrade Existing Systems To Increase Pump Down Speed**
  - **Dynamically Balanced Impellers**
  - **Two Year Warranty**

### **APPLICATIONS:**

- **Vacuum Heat Treating**
- **Vacuum Brazing**
- **Vacuum Coating**
- **Transformer Drying**
- **Degasification Systems**
- **Shelf Drying**
- **Vacuum Casting**
- **E-Beam Welding**

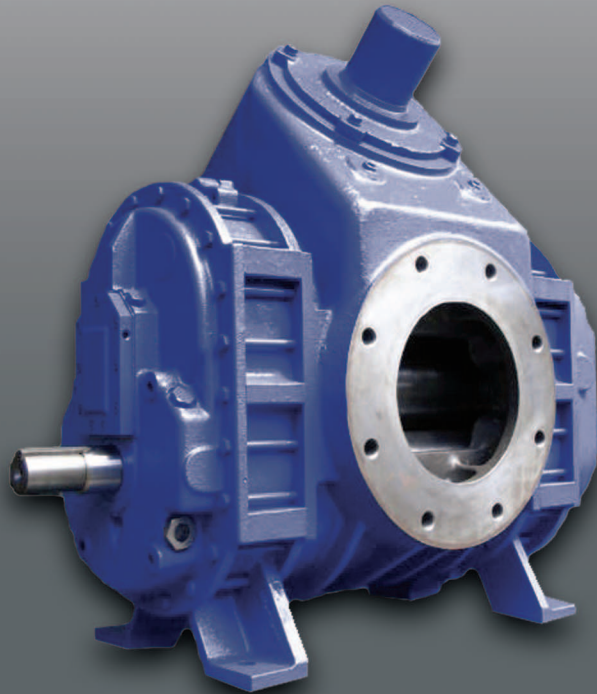

**UNITED VACUUM**

NEW JERSEY - USA • TEL: 888-742-7202  
[www.unitedvacuum.com](http://www.unitedvacuum.com)

# Model: 600 Series

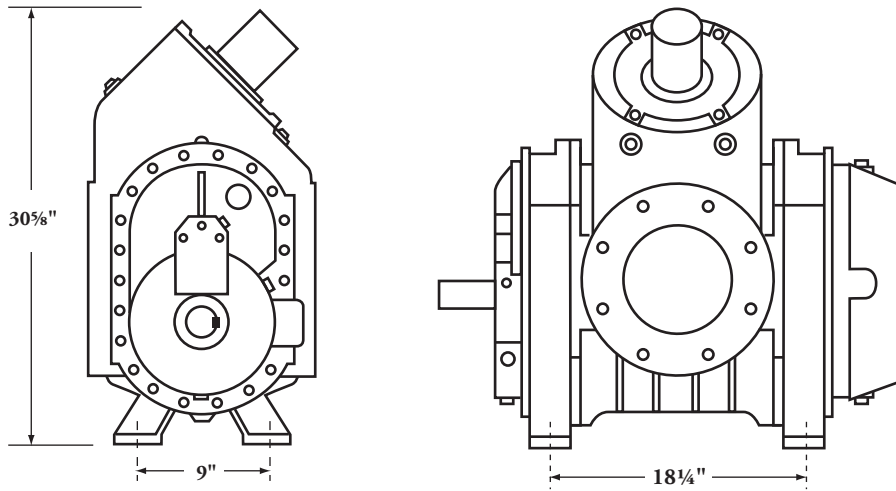

600 Series Specifications	
Free Air Displacement:	.....1300 CFM @ 1750 RPM
Motor:	.....7.5 HP 208/230/460V
Inlet and Outlet:	.....8" ASA
Weight:	.....615 lbs.

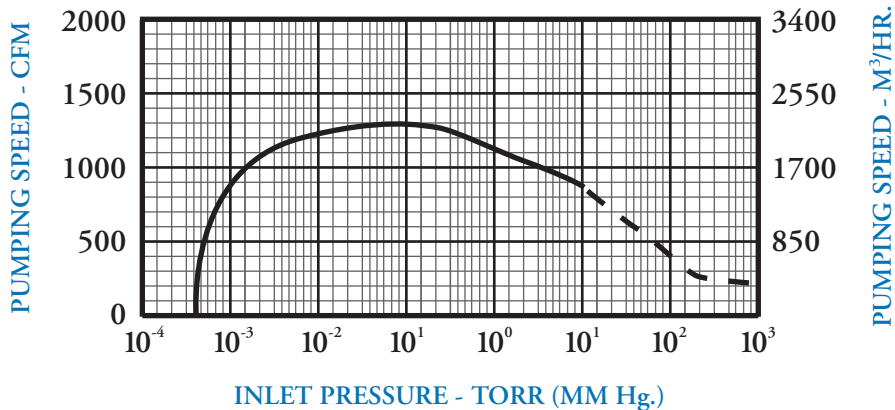

Curve Reflects Speed with 300 CFM Backing Pump

